

**IMPORTANT NOTES ON FITTING YOUR FCD3:**

**WARNING!** Turbosmart recommends that your FCD3 is fitted and tuned by an appropriately qualified technician. Turbosmart accepts no responsibility whatsoever for incorrect installation of this product which can cause serious engine damage if fitted or tuned incorrectly.

Most late model cars have in-built defence mechanisms to guard against increases in boost pressure. Such systems are important but can be an obstacle when increasing boost pressure. The Turbosmart FCD3 will allow boost pressure to be increases above the factory level and prevent momentary shutdown of the fuel injection system.

**CAUTION!** Once the fuel cut defender has been installed, the factory over-boost fuel cut will no longer operate at the factory level. The boost can now be raised to dangerous levels which can destroy your engine if it is not capable of handling higher boost pressures. Be extremely cautious when increasing the boost pressure above the factory level.

**IMPORTANT!** Turbosmart recommends that the Air Fuel (A/F) ratio is checked once the Fuel Cut Defender is set and or boost pressure is increased.

**CONTENTS**

Please check that the following items have been supplied.

Quantity	Description	Use
1	FCD3	Fuel cut defender
2	Self tapping screws	Used to mount the FCD3
2	Washers	Used to mount the FCD3

**FCD3 FRONT PANEL VIEW:**

This view shows the three adjustments on the FCD3.



**IMPORTANT!** – Adjustment dials do not turn 360°, they start at 1 and finish at 10. They will not turn the full 360 degrees so do not force them.

The Graph illustrates the effect of each adjustment dial on the sensor output.

Voltage from sensor into FCD vs. output voltage from FCD to ECU

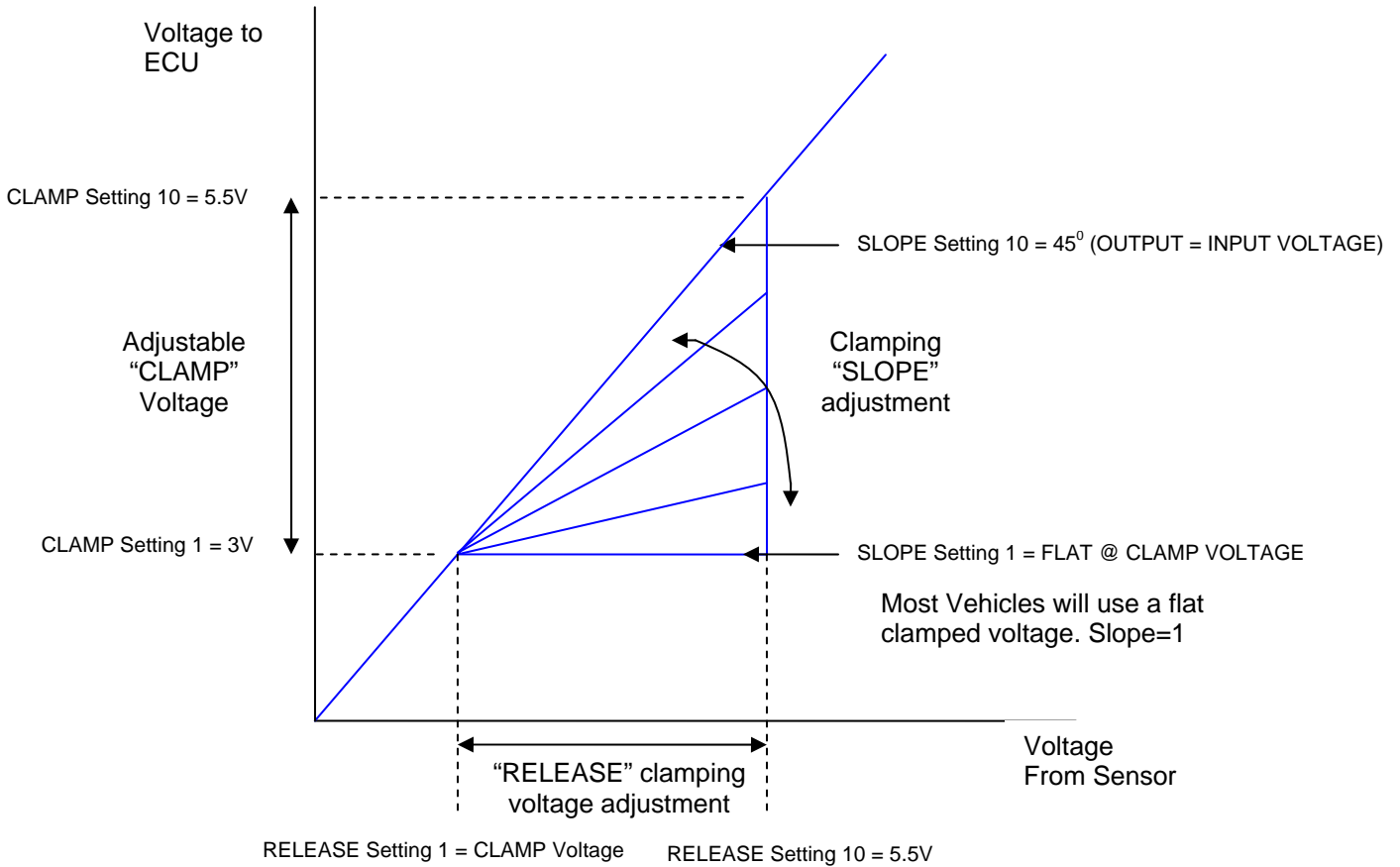

### SETTING EXAMPLES

These setting examples are to **aid in understanding** the various settings of the FCD and **should not be used as a tuning guide**. IMPORTANT! See following instructions for tuning your FCD3.

Voltage from sensor into FCD vs. output voltage from FCD to ECU for settings:  
CLAMP: 1, RELEASE: 6, SLOPE: 1

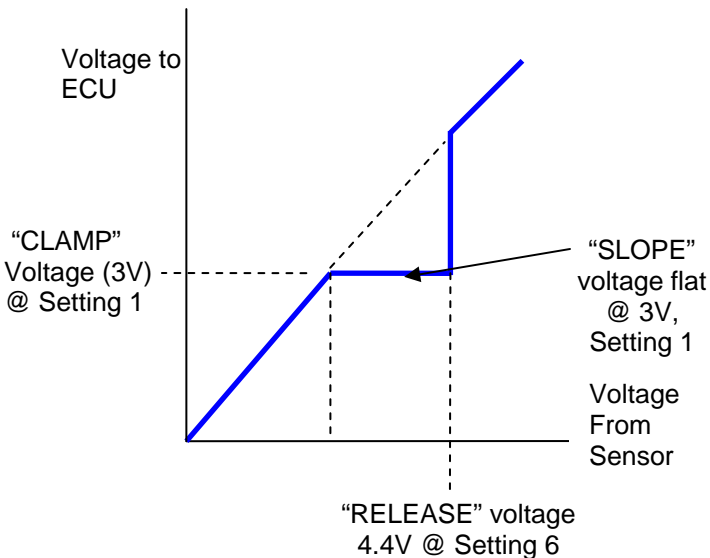

Voltage from sensor into FCD vs. output voltage from FCD to ECU for settings:  
CLAMP: 5, RELEASE: 8, SLOPE: 7

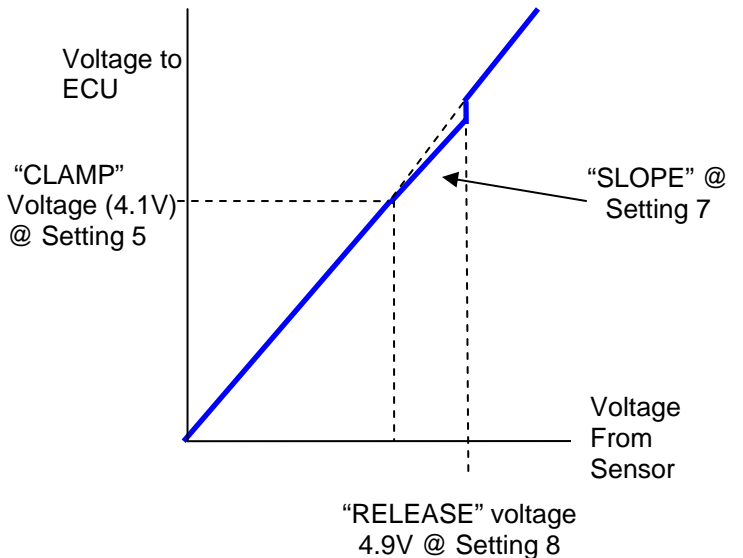

**FITTING INSTRUCTIONS:**

Before installing the FCD3 it is important to determine if the vehicles electronic control unit (ECU) receives its boost reference signal from the manifold absolute pressure (MAP) sensor or air flow meter (AFM). Failure to connect the FCD to the correct sensor could cause severe engine damage. Turbosmart recommends consulting the manufacturer service manuals before installation. The following table should be used as a guide only.

MAKE/MODEL	SENSOR CONNECTION
DAIHATSU – CHARADE GTi	MAP
MAZDA RX7 IV, V, VI	MAP
MITSUBISHI – CORDIA, STARION	MAP
NISSAN – EXA, 200SX, GTIR	AFM
SUBARU – WRX, FORESTER, RS LIBERTY	MAP

**WIRING:**

- RED Wire: Connect to 12V positive supply from ignition switch (not directly from the battery)
- BLACK Wire: Connect to Negative supply (earth on vehicle chassis)
- WHITE Wire: Connect to MAP sensor or AFM meter output signal wire
- BLUE Wire: Connect to ECU boost reference input wire (previously connected to MAP sensor or AFM output)

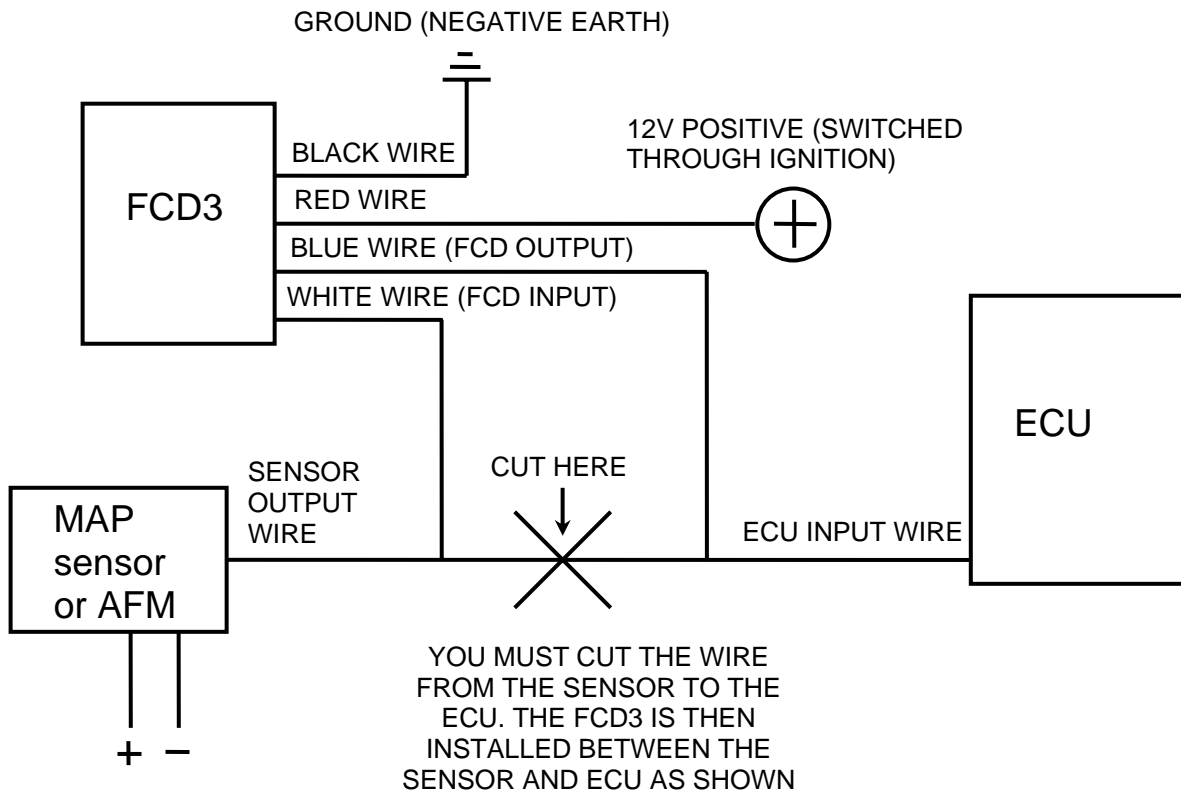

The output wire of your MAP sensor or AFM can be easily located using a digital multimeter or consulting your service manual. When using a digital multimeter ensure the meter is set to read voltage in the 0-10V range. Place the negative probe of your multimeter on the vehicles chassis and with the car idling, slowly rev the engine. With the positive probe you should be able to read a change in output on one of the wires connected to the MAP sensor or AFM with increasing rpm. Alternatively with ignition switched and engine off, blow air through the AFM or apply pressure to the MAP sensor using a mighty vac. This should also give a change in voltage on the sensor output wire. Once you have identified the correct wire the wire should be cut and the input and output of the FCD3 should be connected to the wires as shown in the above diagram.

## **MOUNTING:**

Mount the FCD3 in a suitable location within the cabin using the supplied screws. The unit is not waterproof and should not be mounted under the bonnet.

## **TUNING YOUR FCD3:**

Caution: Do not attempt to drive the vehicle and adjust the Fuel Cut Defender at the same time. Have an assistant to help or stop the vehicle before making any adjustments. Ensure you choose a safe area to carry out any adjustments and never exceed the speed limit. For best results Turbosmart recommends tuning should be performed on a dynamometer where Air-Fuel ratios and boost levels can be checked.

### **IMPORTANT! Before setup the unit should be set to the following settings, Clamp=10, Release=10, Slope=1.**

For most vehicles the setup is quite simple. With the aid of an assistant, drive the vehicle bringing the engine onto full boost until the factory boost cut is activated, taking note of the boost level at which this occurs. Then turn the clamp adjustment dial on the front of the Fuel Cut Defender module ANTI-CLOCKWISE until the indicator light just illuminates. The GREEN LED indicator light should turn on just before the factory boost cut point. Activating the boost cut defender any earlier than this could cause the engine to run "LEAN" resulting in possible engine damage. Turbosmart recommends that the Air Fuel ratio is checked once the Fuel Cut Defender is set and or boost pressure is increased.

With the clamping level set the release voltage or new cut point can be set. When the release dial is set to 10 the unit will release when the sensor signal reaches 5.5V. If you know the boost level that you want the fuel cut to return with the aid of an assistant, drive the vehicle bringing the engine onto full boost at the maximum boost level you want to run before fuel cut. Then adjust the release dial anti-clockwise until the RED LED illuminates and vehicle begins to fuel cut. This dial should be set just above the maximum boost level you require.

For most vehicles the slope should be set to 1. This clamps the voltage coming from the sensor at a constant level and works for most cars except the Nissan Skyline.

## **IMPORTANT NOTES YOUR NISSAN SKYLINE TUNING:**

For skylines it is recommended that the clamping voltage is set to 3, the release is set to 10 and the slope is initially set to 10. This will initially have no effect on the signal from your sensor.

IMPORTANT!! Altering the signal from the Air flow meter can easily cause your engine to run lean. All tuning of the slope should be performed on a dynamometer while A/F ratios are being monitored. Turbosmart accepts no responsibility for serious engine damage cause by running lean.

Note only very small adjustments of the slope knob are required at a time. The procedure for tuning should be as follows:

### **IMPORTANT! Start with initial power run with initial setting of, Clamp=3, Release=10, Slope=10.**

Reduce the slope ¼ of a notch and repeat power run making sure to check the A/F ratio. Check the power curve and note any improvement.

Reduce slope by another ¼ of a notch and repeat again being extremely watchful of the A/F ratio. Repeat this process until the best power curve is found while maintaining an acceptable A/F Ratio.

### **IMPORTANT! It is very important the A/F ratios are checked and Turbosmart accepts no responsibility for the incorrect tuning or installation of this product.**

#### **NOTE – PLEASE READ ATTACHED TERMS AND CONDITIONS.**

Subject to the attached terms and conditions:

#### **Warranty**

Turbosmart warrants its products to be free from faults or defects for the life of the product. \*

\* Subject to Turbosmart trading terms and conditions

#### **Warning!**

Incorrect use of this product may result in damage to your vehicle. Failure to observe any notes or recommendations may result in incorrect use of this product. This product is intended for use in off-road racing only. Turbosmart will accept no responsibility for the incorrect installation or use of this product.

#### **Disclaimer!**

Turbosmart will not be held responsible for any damage caused to property or person, directly or indirectly related to the use of any Turbosmart products.

# **TURBOSMART®**

**FCD3 FUEL CUT DEFENDER INSTRUCTIONS**  
**THE TURBOSMART PLEDGE**

**PART NUMBER**  
**FG-FCD-003**

**DO NOT USE ANY TURBOSMART PRODUCT UNTIL YOU HAVE CAREFULLY READ AND UNDERSTOOD THE FOLLOWING AGREEMENT.**

- A.** Please call if you have any questions or do not understand this agreement. Refer to our brochure, website or catalogue for terms and conditions and further information regarding your product. Turbosmart appreciates your business and pride ourselves on our customer service. We are always happy to offer you advice and will provide you with help in any way we can. The purpose of this agreement is to avoid any problems or hard feelings.
- B.** We sometimes make mistakes, as do our dealers, distributors and suppliers. Even customers can sometimes order the wrong parts. Do not use, modify, install, trial assemble, nick, drop, scratch or adjust any part until you first check for any damage. Damage must be reported immediately. **NO EXCEPTIONS.** If there are any components missing please contact your authorised reseller immediately upon receipt of your shipment. Missing components must be reported within five (5) business days of receipt. Parts returned for any reason **MUST BE IN RESALABLE CONDITION.** It is YOUR responsibility, "THE CUSTOMER" to carefully package any returns to avoid shipping damage. Insurance is highly recommended. Credit cannot be issued for damaged goods.

**C. Warranty**

1. Turbosmart Pty Ltd warrants that the quality of the products it designs and manufactures to be free of defects in material and workmanship. This limited warranty is extended only to the original purchaser and may not be transferred or assigned. This limited warranty applies to any product, which after careful inspection by Turbosmart Pty Ltd, after receipt of the product from our authorised reseller, is found, in the opinion of Turbosmart, to have a defect in either material or workmanship. Any modifications to the product will void any and all warranties. Before installation, check any applicable new car warranty. Turbosmart Pty Ltd is not responsible for voiding any original manufactures warranty.
2. Subject to the conditions of warranty set out below, if the product is found to be defective in either workmanship or material by Turbosmart then Turbosmart will, in its sole discretion, either repair or replace the product free of charge.

**D. Conditions of Warranty**

1. All warranty claims must be returned to the authorised reseller, you must return the product and sales receipt, at your own expense, accompanied by a letter stating the reason for the claim. Proof of purchase must be provided with any warranty claim and will be verified with the authorised reseller from which the product was purchased.
2. The product must not have had its serial number removed, defaced or changed, its casing opened or have been tampered with in any other way.
3. Failure of the product must not be due to misuse, improper installation or other abuse or misuse. In the event that any product is found to be faulty due to abuse, misuse or improper installation, then the repair of the product will be charged to the purchaser at Turbosmart's current rates of charge.
4. Turbosmart will not be responsible for damage or loss caused during shipping.
5. All other warranties, terms and conditions, whether express or implied in relation to the state, quality or fitness of the goods or of every other kind and whether arising by use, statute or otherwise are hereby excluded.

**E. Exclusion of Liability**

1. Turbosmart is not liable to the purchaser in contract or in tort or pursuant to statute arising out of, or in connection with, or relating to:
- (a) the performance of the products or any breach of these conditions; or
  - (b) any fact, matter or thing relating to the products; or
  - (c) any error (whether negligent or in breach of contract or not) in information supplied to the purchaser or a user before or after the date of the purchaser's or user's use of the products; or
  - (d) any error or defect in the products or errors or faults caused by any components or consumables supplied by any third person which causes failure of the products.
2. Turbosmart's sole obligation under these terms and conditions is to repair or replace the products which are found to be defective pursuant to the express warranty and in no event shall Turbosmart be liable for any other claims or damages including, but not limited to, claims for faulty design, negligent or misleading advice, damages arising from loss or use of the products and any indirect, special or consequential damages or injury to any person or other entity.
3. If the product is a product not ordinarily acquired for personal, domestic or household use or consumption pursuant to the Trade Practices Act and similar provisions of relevant State legislation, Turbosmart limits its liability to payment of an amount equal to the lowest of:
- (a) the cost of replacing the product;
  - (b) the cost of repair of the product;
  - (c) the cost of having the product repaired or replaced.
4. Turbosmart is not liable for default or failure in performance of its obligations resulting directly or indirectly from Acts of God, civil or military authority, war, accidents, fires, explosions, earthquakes, floods, strikes, labour disputes, shortage of suitable parts, components, materials, chemicals, labour or transportation or any other cause beyond the reasonable control of Turbosmart.
5. The purchaser hereby releases and indemnifies Turbosmart from all and any claims, liability, loss or expense or demand arising out of or in connection with the products or the installation, use or performance of the product.

**EXCEPT FOR THOSE OBLIGATIONS ASSUMED HEREIN, TURBOSMART PTY LTD ASSUMES NO OTHER OBLIGATIONS IN CONNECTION WITH THE SALE OF ITS PRODUCTS.**

**IN THE EVENT THAT THE INDIVIDUAL PURCHASER DOES NOT AGREE WITH THIS AGREEMENT THEN THE PURCHASER MAY PROMPTLY RETURN THIS PRODUCT, IN A NEW AND UN-USED CONDITION, WITH A DATED PROOF OF PURCHASE, TO THE PLACE OF PURCHASE WITHIN SIXTY (60) DAYS FROM THE DATE OF PURCHASE FOR A FULL REFUND.**

**THE PURCHASER ACKNOWLEDGES THAT PRIOR TO THE INSTALLATION AND USE OF THE PRODUCT THE PURCHASER HAS CONDUCTED A THOROUGH EXAMINATION OF THE PRODUCT.**

**THE INSTALLATION OF THIS PRODUCT INDICATES THAT THE INDIVIDUAL PURCHASER HAS READ AND UNDERSTOOD THIS AGREEMENT AND ACCEPTS ITS TERMS AND CONDITIONS.**

**Happy motoring!**

**The Turbosmart Team.**